

**SMD QUARTZ CRYSTAL RESONATOR**
**石英晶体谐振器**

**4 Pad Version 5.0x3.2 mm**

- ±10 ppm type available
- Excellent Reliability Performance
- EMI shielding possible by grounded lid
- Reflow soldering temperature: 260°C max
- Ceramic Seam Weld package

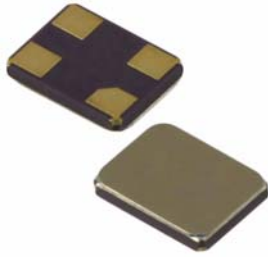

RoHS compliant

**★ PARAMETERS**
**技术参数**

PARAMETERS	参数	SPECIFICATION 规格
Frequency Range	频率范围	8~54MHz
Operation Mode	振动模式	Fundamental
Loading Capacitance	负载电容	18pF Std. 8 to 32pF Series available
Drive Level	激励电平	10 μ W (300 μ W Max)
Frequency Tolerance	频率偏差	±10ppm~±30ppm (at 25°C)
Equivalent Resistance	谐振电阻	100 Ω Max
Frequency Stability	频率稳定性	±10ppm~±50ppm
Operating Temp. Range:	工作温度范围	-10~+60°C to -40~+85°C
Storage Temp. Range:	储存温度范围	-55~+125°C

© All specification subject change without notice. 规格变化, 恕不另行通知。

**★ FREQUENCY STABILITY VS. TEMPERATURE 频率温度特性**
**★ ESR (SERIES RESISTANCE RS)**

Operation Temperature Range	Frequency Stability				
	±10ppm	±15ppm	±20ppm	±30ppm	±50ppm
-10°C~+60°C	●	○	○	○	○
-20°C~+70°C	○	○	●	○	○
-40°C~+85°C		○	○	●	○

Frequency	Vibration Mode	ESR
8-9.999MHz	AT CUT/FUND.	100Ω(MAX)
10-11.999MHz	AT CUT/FUND.	60Ω(MAX)
12-15.999MHz	AT CUT/FUND.	50Ω(MAX)
16-24.999MHz	AT CUT/FUND.	40Ω(MAX)
25-54.000MHz	AT CUT/FUND.	30Ω(MAX)

● standard ○ available

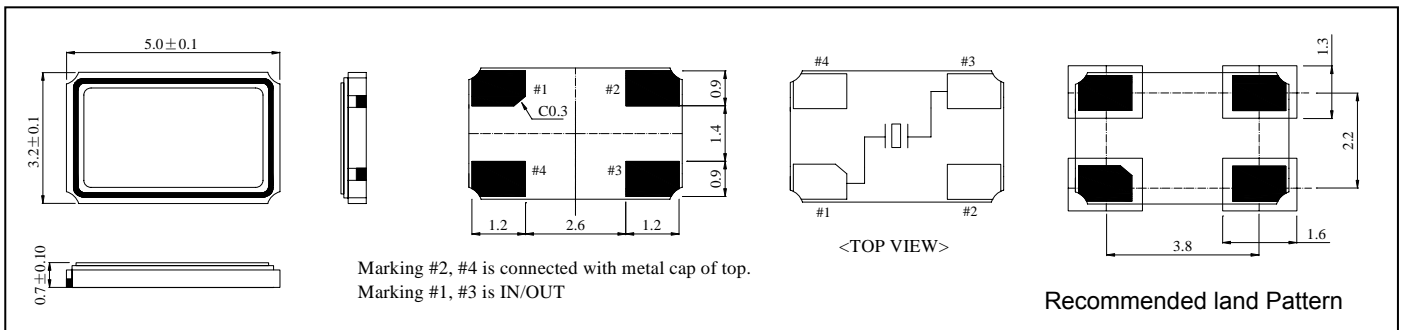
**★ DIMENSIONS & LAND PATTERN LAYOUT (Unit: mm) 外形尺寸**

**★ PART NUMBER GUIDE 部件号示例 e.g. FTX12.000M18SM5S-20/20B (\*SM5S=5.0×3.2 SMD SEAM TYPE)**

Logo	Quartz Crystal Resonator 石英晶体谐振器	Frequency 频率 Hz	Load Capacitance 负载电容 pF	Package 盒型	Frequency Tolerance 常温频差 ppm	Frequency Stability 温度频差 ppm	Operating Temp. Range 工作温度
FT	X	12.000M	18	SM5S	20	20	B

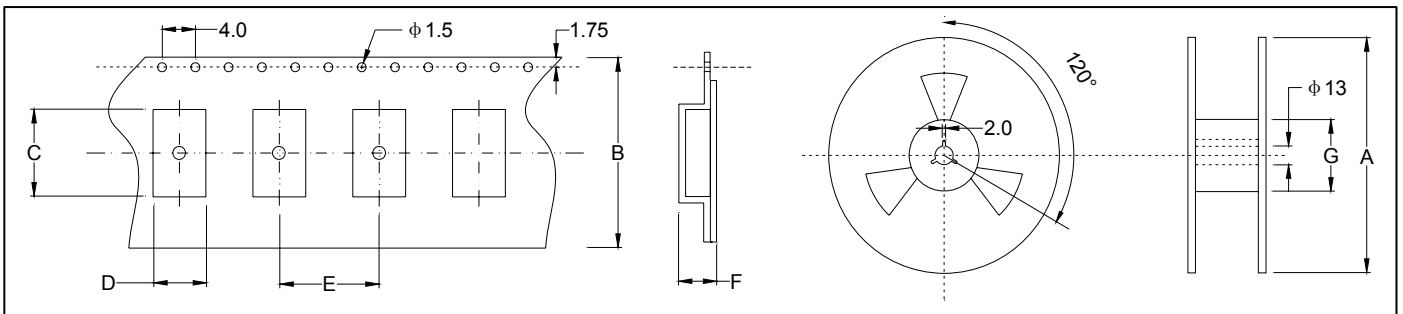
Definition	Description
Operating Temperature Range	A: -10~+60°C
	B: -20~+70°C
	C: -30~+80°C
	D: -40~+85°C
	E: Customer specified

**★ TAPING SPECIFICATION (Unit: mm) 编带规格**

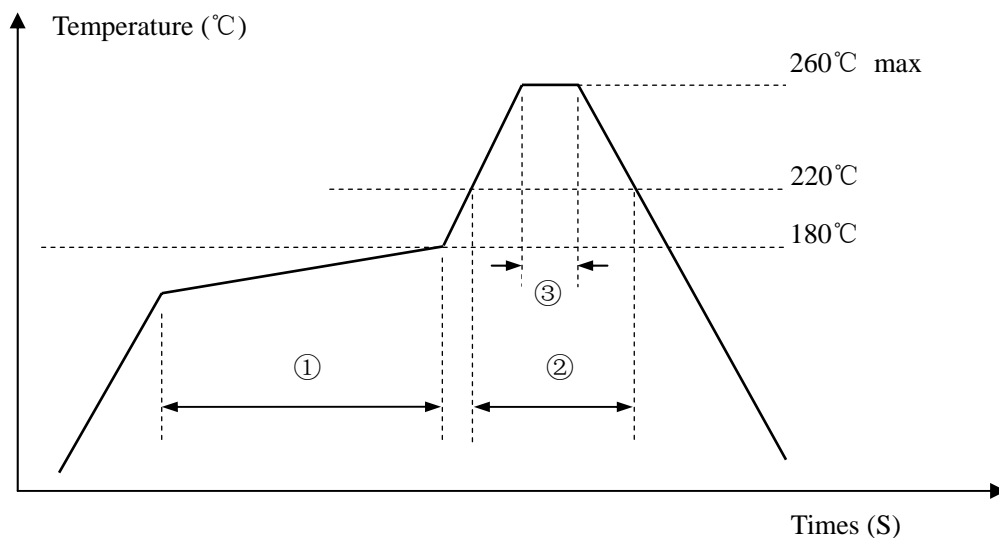
	A	B	C	D	E	F	G
SMD5032	178±2.0	12.0±0.3	5.40±0.10	3.60±0.10	8.0±0.1	1.1±0.1	60.5±1.0
1000 pcs per reel							

**★ REFLOW SOLDERING PROFILE 回流焊特性**

Pb free reflow A	①	Preheat	160~180°C	120sec. max
	②	Primary heat	220°C	60sec. max
	③	Peak	260°C	10sec. max.