

SMD QUARTZ CRYSTAL RESONATOR

石英晶体谐振器

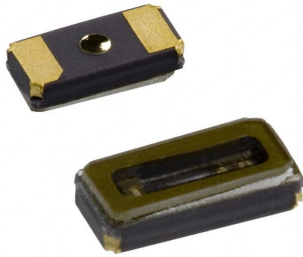

2 Pad Version 3.2×1.5 mm

- Tuning fork crystal in standard package
- 32.768 KHz standard
- ±20 ppm Standard
- Excellent Reliability Performance
- Reflow soldering temperature: 260°C max



RoHS compliant

★ PARAMETERS 技术参数

PARAMETERS	参数	SPECIFICATION 规格
Frequency Range	频率范围	32.768KHz
Loading Capacitance	负载电容	12.5pF Std. 7 pF available
Drive Level	激励电平	1.0 μ W Max
Frequency Tolerance	频率偏差	±20ppm (at 25°C)
Equivalent Resistance	谐振电阻	70K Ω Max
Temperature coefficient	温度曲线系数	-0.04×10 ⁻⁶ /°C ² max
Operating Temp. Range:	工作温度范围	-40~+85°C
Storage Temp. Range:	储存温度范围	-55~+125°C
Aging (25°C, First Year)	老化率	±3ppm max

© All specification subject change without notice. 规格变化, 恕不另行通知。

★ DIMENSIONS & LAND PATTERN LAYOUT (Unit: mm) 外形尺寸

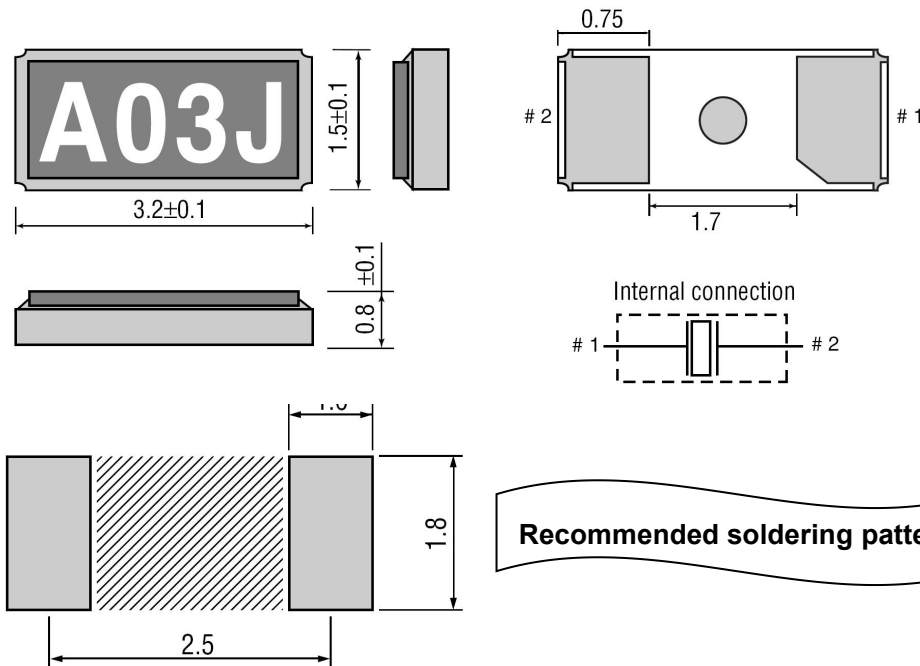

★ PART NUMBER GUIDE 部件号示例 e.g. JXX32.768K12.5SM3 (*SM3=3.2×1.5 SMD)

	Quartz Crystal Resonator 石英晶体谐振器	Frequency 频率	Load Capacitance 负载电容	Package 盒型
JX	X	32.768KHz	12.5	SM3

★ TAPING SPECIFICATION (Unit: mm) 编带规格

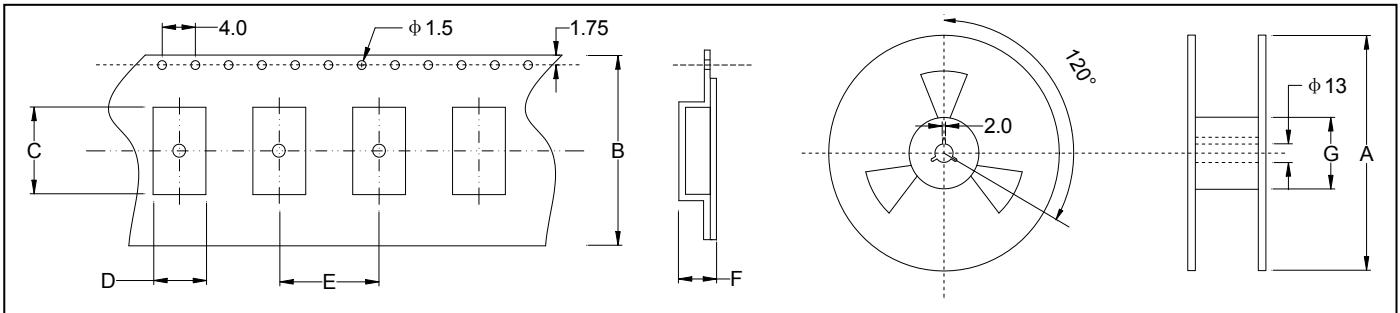

	A	B	C	D	E	F	G
SMD3.2×1.5	180	12	3.45	1.75	4.0	1.0	60
3000 pcs per reel							

★ REFLOW SOLDERING PROFILE 回流焊特性

