

SMD QUARTZ CRYSTAL RESONATOR

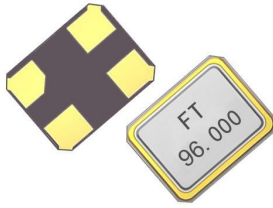

4 Pad Version 1.6×1.2 mm

- ±10 ppm type available
- Excellent Reliability Performance
- EMI shielding possible by grounded lid
- Reflow soldering temperature: 260°C max
- Ultra-small package



RoHS compliant

★ PARAMETERS

PARAMETERS	SPECIFICATION
Frequency Range	24~96MHz
Operation Mode	Fundamental
Loading Capacitance	9pF Std. 8 to 32pF / Series available
Drive Level	10 μ W (100 μ W Max)
Frequency Tolerance	±10ppm~±30ppm (at 25°C)
Equivalent Resistance	150Ω Max
Frequency Stability	±10ppm~±30ppm
Operating Temp. Range:	-10~+60°C to -40~+85°C
Storage Temp. Range:	-55~+125°C

○ All specification subject change without notice.

★ FREQUENCY STABILITY VS. TEMPERATURE

Operation Temperature Range	Frequency Stability			
	±10ppm	±15ppm	±20ppm	±30ppm
-10°C~+60°C	●	○	○	○
-20°C~+70°C	○	○	●	○
-40°C~+85°C		○	○	●

● standard ○ available

★ ESR (SERIES RESISTANCE RS)

Frequency	Vibration Mode	ESR
24-25.999MHz	AT CUT/FUND.	150Ω Max.
26-39.999MHz	AT CUT/FUND.	120Ω Max.
40-96.000MHz	AT CUT/FUND.	100Ω Max.

★ DIMENSIONS & LAND PATTERN LAYOUT (Unit: mm)

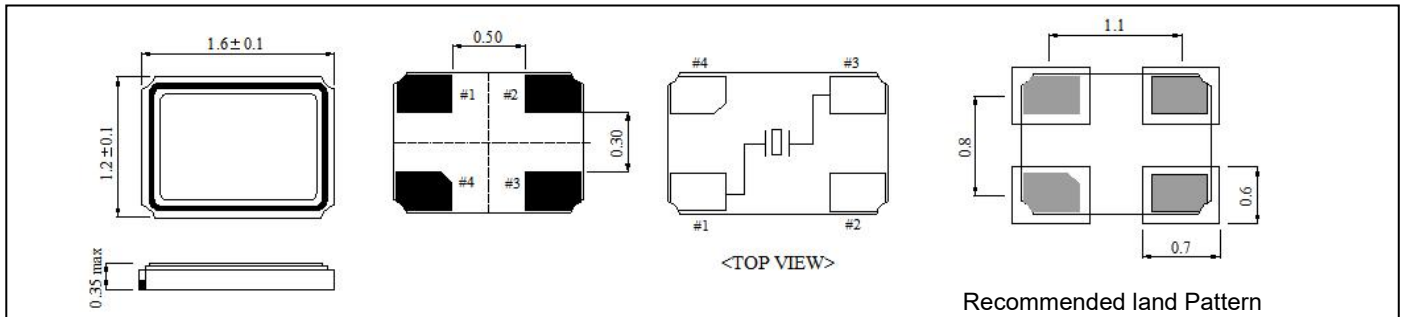

★ PART NUMBER GUIDE e.g. FTX26.000M9SM1S-10/10B (*SM1S=1.6×1.2 SMD SEAM TYPE)

Logo	Quartz Crystal Resonator	Frequency Hz	Load Capacitance pF	Package	Frequency Tolerance ppm	Frequency Stability ppm	Operating Temp. Range
FT	X	26.000M	9	SM1S	10	10	B

Definition	Description	
Operating Temperature Range	A: -10~+60°C	B: -20~+70°C
	C: -30~+80°C	D: -40~+85°C
	E: -30~+105°C	F: -40~+105°C
	G: -40~+125°C	S: Customer specified

★ TAPING SPECIFICATION (Unit: mm)

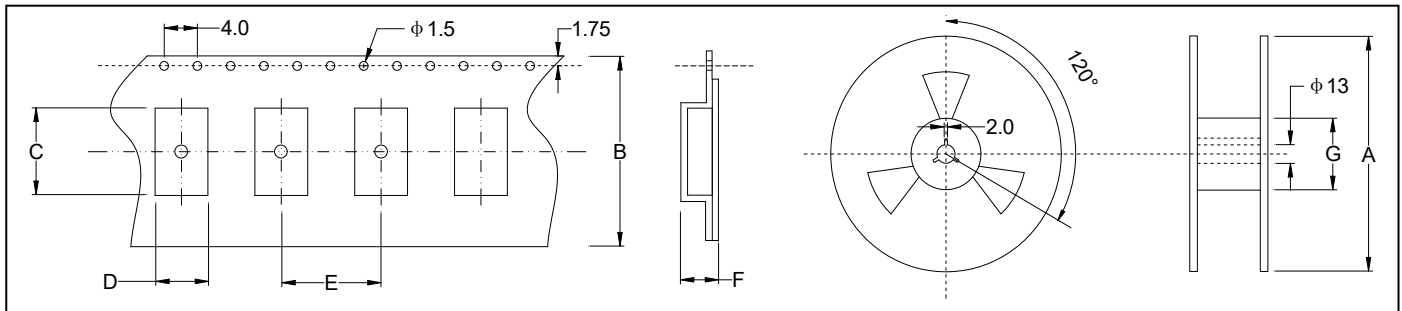

	A	B	C	D	E	F	G
SMD1612	178±2.0	8.0±0.3	1.85±0.05	1.45±0.05	4.0±0.1	0.6±0.1	60.5±1.0
3000 pcs per reel							

★ REFLOW SOLDERING PROFILE

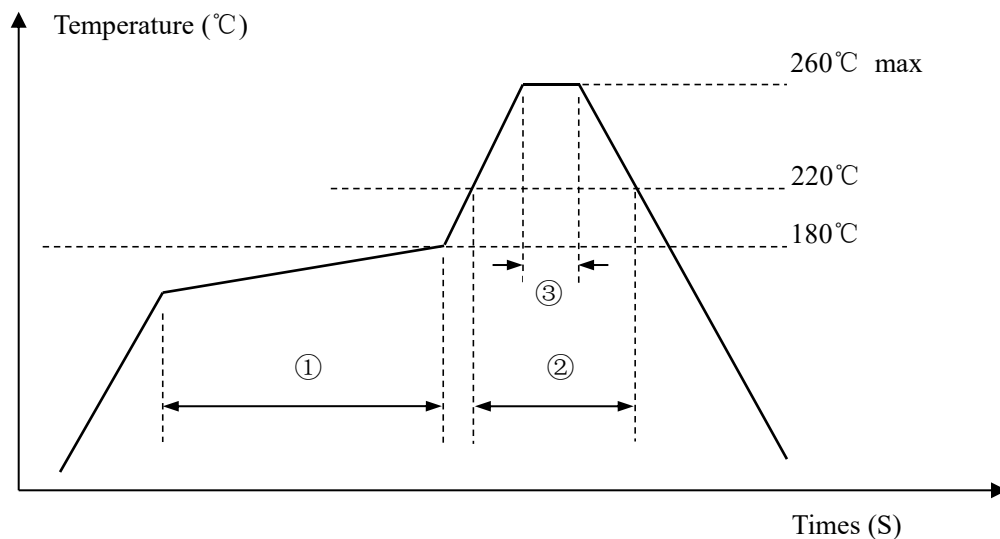

Pb free reflow A	①	Preheat	160~180°C	120sec. max
	②	Primary heat	220°C	60sec. max
	③	Peak	260°C	10sec. max.