

**SMD QUARTZ CRYSTAL OSCILLATOR**
**石英晶体振荡器**

**4 Pad Version 7.0x5.0 mm**

- ±20 ppm type available
- Excellent Reliability Performance
- EMI shielding possible by grounded lid
- Reflow soldering temperature: 260°C max
- Ceramic Seam Weld package



RoHS compliant

**★ PARAMETERS**
**技术参数**

PARAMETERS	参数	SPECIFICATION 规格
Frequency Range	频率范围	1~125MHz
Supply voltage	工作电压	1.8V、2.5V、2.8V、3.3V、5.0V
Input Current	输入电流	See Below
Frequency Stability Overall	频率稳定性	±20ppm~±50ppm
Operating Temp. Range	工作温度范围	-10~+60°C to -40~+85°C
Storage Temp. Range	储存温度范围	-55~+125°C
Output Load	输出负载	HCMOS/TTL (15pF~30pF/10TTL)
Symmetry	占空比	45% ~ 55% typ. (40% ~ 60% max.) at 0.5×Vdc
Start-up time	起振时间	10mS max
Enable/ Disable Function	三态控制	O/E or E/D

◎ All specification subject change without notice. 规格变化, 恕不另行通知。

**★ FREQUENCY STABILITY VS. TEMPERATURE 频率温度特性**

Operation Temperature Range	Frequency Stability			
	±20ppm	±25ppm	±30ppm	±50ppm
-10°C~+60°C	○	●	○	○
-20°C~+70°C	○	○	●	○
-40°C~+85°C	○	○	○	●

● standard ○ available

**★ Rise & Fall TIME MAX. 上升/下降时间**

Frequency	Rise & Fall Time	Note
1.0-9.9 MHz	6nS max	rise time: 0.1 Vdc ~ 0.9 Vdc
10.0-39.9 MHz	5nS max	
40.0-69.9 MHz	4nS max	fall time: 0.9 Vdc ~ 0.1 Vdc
70.0-125.0 MHz	3nS max	

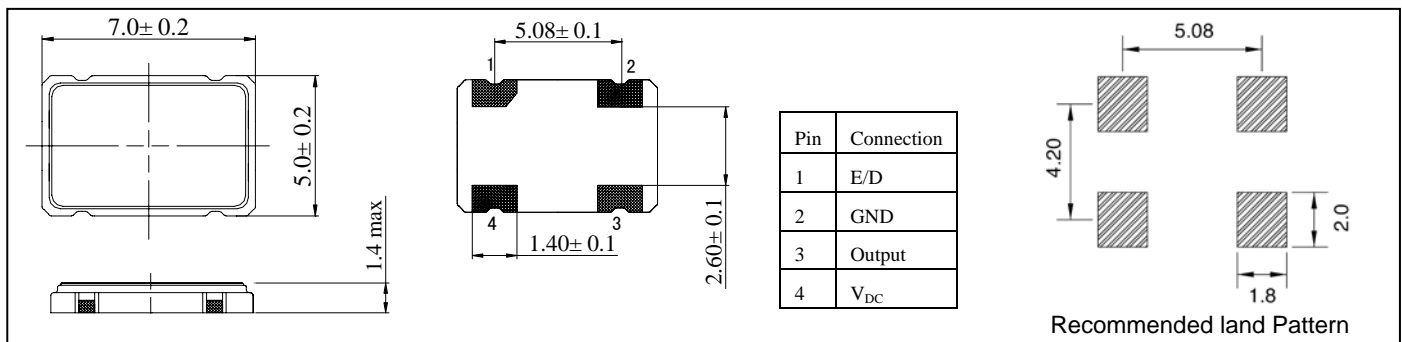
**★ DIMENSIONS & LAND PATTERN LAYOUT (Unit: mm) 外形尺寸**

**★ PART NUMBER GUIDE 部件号示例**

e.g. FXO12.000AA3.3SM3 (\*SM3=3.2×2.5 SMD TYPE)

	Quartz Crystal Oscillator 石英晶体振荡器	Frequency 频率	Frequency Stability 频率稳定度	Operating Temp. 工作温度	Supply voltage 工作电压	Package 盒型
F	XO	12.000	A	A	3.3	SM7

Definition	Description	Definition	Description
Frequency Stability 频率稳定度	A: $\pm 25\text{ppm}$	Operating Temp. 工作温度	A: $0\sim+70^{\circ}\text{C}$
	B: $\pm 50\text{ppm}$		B: $-20\sim+70^{\circ}\text{C}$
	C: $\pm 100\text{ppm}$		C: $-40\sim+85^{\circ}\text{C}$
	D: Customer specified		D: Customer specified

**★ INPUT CURRENT 工作电流**

Vdc=5.0V				Vdc=3.3V			
15pF load		30pF load		15pF load		30pF load	
1.0 ~ 19.9 MHz	12 mA	1.0 ~ 19.9 MHz	15 mA	1.0 ~ 19.9 MHz	8 mA	1.0 ~ 19.9 MHz	15 mA
20.0 ~ 39.9 MHz	20 mA	20.0 ~ 39.9 MHz	30 mA	20.0 ~ 39.9 MHz	15 mA	20.0 ~ 39.9 MHz	25 mA
40.0 ~ 59.9 MHz	30 mA	40.0 ~ 59.9 MHz	35 mA	40.0 ~ 59.9 MHz	25 mA	40.0 ~ 59.9 MHz	30 mA
60.0 ~ 79.9 MHz	45 mA	50.0 ~ 80.0 MHz	55 mA	60.0 ~ 79.9 MHz	35 mA	60.0 ~ 79.9 MHz	35 mA
80.0 ~ 125.0MHz	60 mA			80.0 ~ 125.0MHz	45 mA		

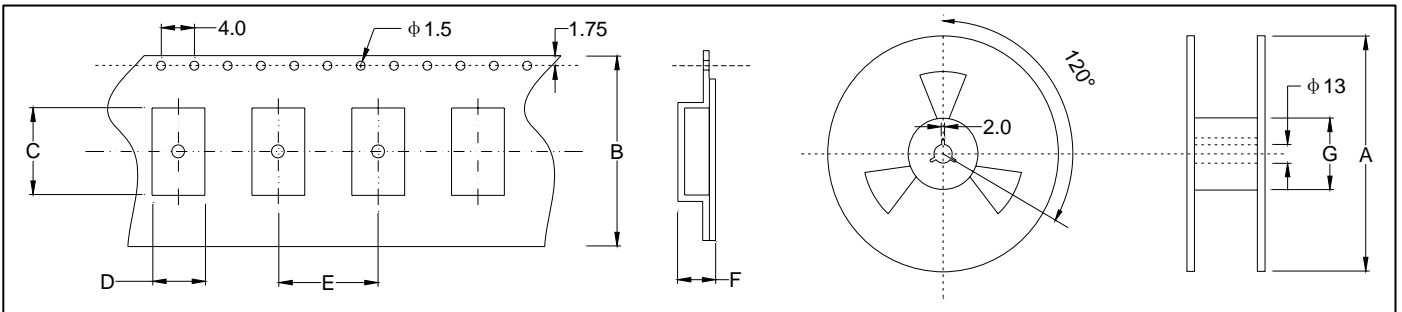
**★ TAPING SPECIFICATION (Unit: mm) 编带规格**

	A	B	C	D	E	F	G
OSC-SMD7050	$178\pm 2.0$	$16.0\pm 0.3$	$7.40\pm 0.15$	$5.40\pm 0.15$	$8.0\pm 0.1$	$2.2\pm 0.1$	$60.5\pm 1.0$
1000 pcs per reel							

**★ REFLOW SOLDERING PROFILE 回流焊特性**
