

SMD QUARTZ CRYSTAL OSCILLATOR
石英晶体振荡器

4 Pad Version 2.5x2.0 mm

- ±20 ppm type available
- Excellent Reliability Performance
- EMI shielding possible by grounded lid
- Reflow soldering temperature: 260°C max
- Ceramic Seam Weld package



RoHS compliant

★ PARAMETERS
技术参数

| PARAMETERS | 参数 | SPECIFICATION 规格 |
|-----------------------------|--------|--|
| Frequency Range | 频率范围 | 2~50MHz |
| Supply voltage | 工作电压 | 1.8V、2.5V、2.8V、3.3V |
| Input Current | 输入电流 | See Below |
| Frequency Stability Overall | 频率稳定性 | ±20ppm~±50ppm |
| Operating Temp. Range | 工作温度范围 | -10~+60°C to -40~+85°C |
| Storage Temp. Range | 储存温度范围 | -55~+125°C |
| Output Load | 输出负载 | HCMOS/TTL (15pF~30pF/10TTL) |
| Symmetry | 占空比 | 45% ~ 55% typ. (40% ~ 60% max.) at 0.5×Vdc |
| Start-up time | 起振时间 | 10mS max |
| Enable/ Disable Function | 三态控制 | O/E or E/D |

◎ All specification subject change without notice. 规格变化, 恕不另行通知。

★ FREQUENCY STABILITY VS. TEMPERATURE 频率温度特性

| Operation Temperature Range | Frequency Stability | | | |
|-----------------------------|---------------------|--------|--------|--------|
| | ±20ppm | ±25ppm | ±30ppm | ±50ppm |
| -10°C~+60°C | ○ | ● | ○ | ○ |
| -20°C~+70°C | ○ | ○ | ● | ○ |
| -40°C~+85°C | | | | ● |

● standard ○ available

★ Rise & Fall TIME MAX. 上升/下降时间

| Frequency | Rise & Fall Time | V _{DC} | Rise & Fall Time | V _{DC} |
|---------------|------------------|-----------------|------------------|-----------------|
| 2.0-9.9 MHz | 5nS max | 3.3V | 6nS max | 1.8V |
| 10.0-19.9 MHz | 5nS max | | 5nS max | |
| 20.0-31.9 MHz | 5nS max | | 4nS max | |
| 32.0-50MHz | 5nS max | | 4nS max | |

★ DIMENSIONS & LAND PATTERN LAYOUT (Unit: mm) 外形尺寸

| Pin | Connection |
|-----|-------------------------|
| 1 | Tri-state or no connect |
| 2 | GND |
| 3 | Output |
| 4 | V _{DC} |

Recommended land Pattern

★ PART NUMBER GUIDE 部件号示例

e.g. FXO12.000AA3.3SM3 (*SM3=3.2×2.5 SMD TYPE)

| | Quartz Crystal Oscillator 石英晶体振荡器 | Frequency 频率 | Frequency Stability 频率稳定度 | Operating Temp. 工作温度 | Supply voltage 工作电压 | Package 盒型 |
|---|--------------------------------------|-----------------|------------------------------|-------------------------|------------------------|---------------|
| F | XO | 12.000 | A | A | 3.3 | SM2 |

| Definition | Description | Definition | Description |
|------------------------------|------------------------|-------------------------|---------------------------------|
| Frequency Stability 频率稳定度 | A: $\pm 25\text{ppm}$ | Operating Temp. 工作温度 | A: $0\sim+70^{\circ}\text{C}$ |
| | B: $\pm 50\text{ppm}$ | | B: $-20\sim+70^{\circ}\text{C}$ |
| | C: $\pm 100\text{ppm}$ | | C: $-40\sim+85^{\circ}\text{C}$ |
| | D: Customer specified | | D: Customer specified |

★ INPUT CURRENT 工作电流

| Vdc=3.3V | | Vdc=2.5V | | Vdc=1.8V | |
|-----------------|-------|-----------------|-------|-----------------|-------|
| 2.0 ~ 9.9 MHz | 7 mA | 2.0 ~ 9.9 MHz | 6 mA | 2.0 ~ 9.9 MHz | 3 mA |
| 10.0 ~ 19.9 MHz | 7 mA | 10.0 ~ 19.9 MHz | 8 mA | 10.0 ~ 19.9 MHz | 5 mA |
| 20.0 ~ 31.9 MHz | 12 mA | 20.0 ~ 31.9 MHz | 8 mA | 20.0 ~ 31.9 MHz | 5 mA |
| 32.0 ~ 50.0 MHz | 20 mA | 32.0 ~ 50.0 MHz | 20 mA | 32.0 ~ 50.0 MHz | 10 mA |

★ TAPING SPECIFICATION (Unit: mm) 编带规格

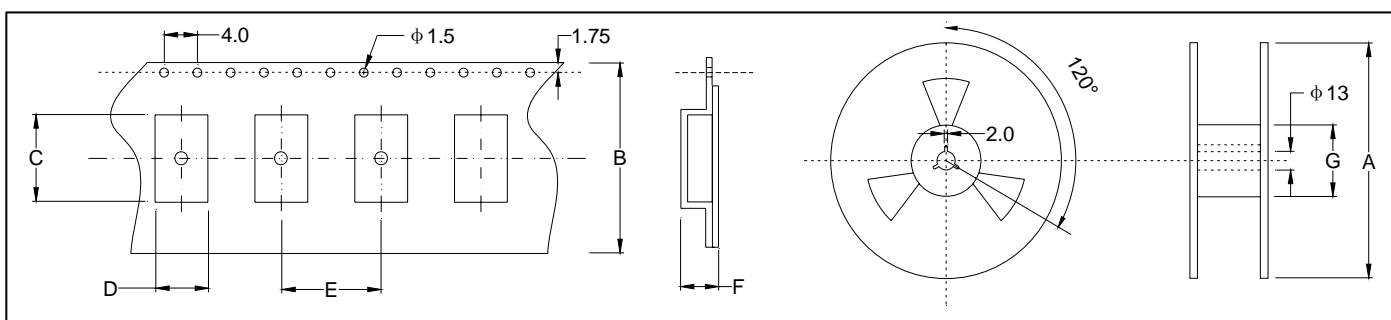

| | A | B | C | D | E | F | G |
|-------------------|--------------|--------------|----------------|----------------|--------------|---------------|---------------|
| OSC-SMD2520 | 178 ± 2.0 | 8.0 ± 0.2 | 2.80 ± 0.10 | 2.30 ± 0.10 | 4.0 ± 0.1 | 1.15 ± 0.1 | 60.5 ± 1.0 |
| 3000 pcs per reel | | | | | | | |

★ REFLOW SOLDERING PROFILE 回流焊特性

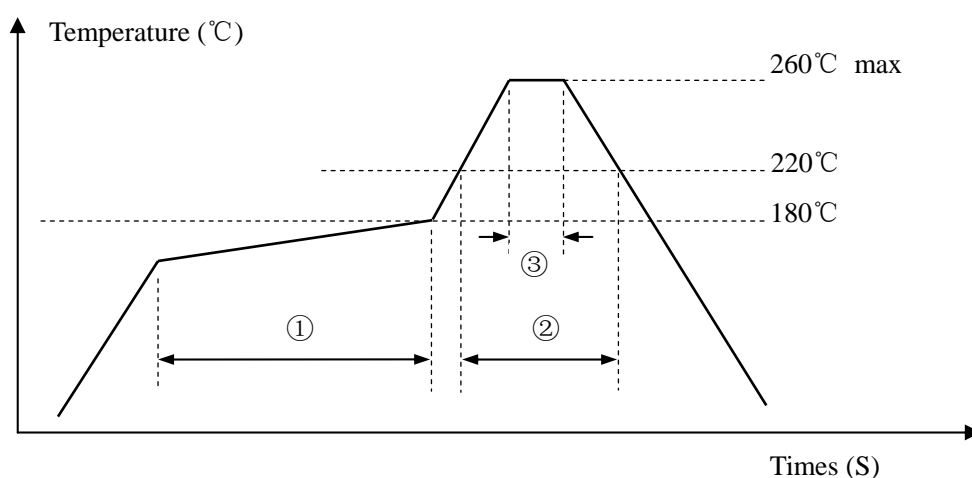

| | | | | |
|---------------------|---|--------------|-----------|-------------|
| Pb free reflow A | ① | Preheat | 160~180°C | 120sec. max |
| | ② | Primary heat | 220°C | 60sec. max |
| | ③ | Peak | 260°C | 10sec. max. |